



15W LED FOG LAMP

4" LED FOG LAMP

Tech Details

LED Type	Epistar / CREE
Power	15W
LED Quantity	5 pcs
Light Colour	White
Oper. Voltage	DC 10-30V
Color Temp.	White : 6500-7000K
Lumen Flux	1500 LM
Body Material	Die Cast Alu Alloy
Lens Material	PMMA
IP Grade	IP67

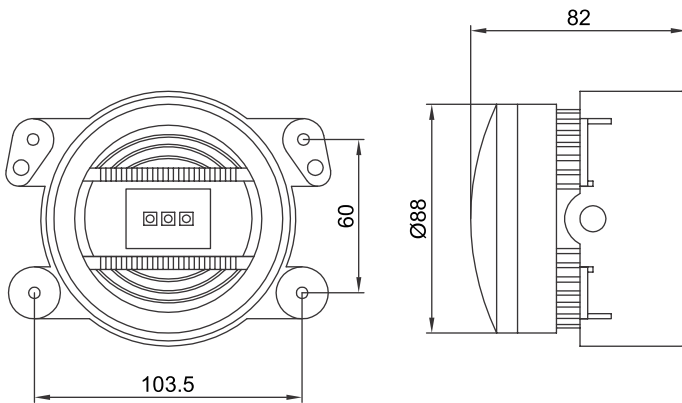

Application: Trucks, Heavy Duty, Tractors, Forklifts, Road Construction, Mining, Drilling, Forestry, Agriculture, Earth Moving etc.

Tech Details

- New generation of LED Light, round and super compact design equipped with 5 pcs of 3W Epistar LED which produces 1500 Lumens, rather high output.
- The durable die-cast aluminum housing to stand up to the hardest conditions.
- Unique and special heat sink design on the periphery and the back for superior heat dissipation. To prolong the life of LEDs to its full 50,000 hours potential, that means it never need change bulb again.
- IP67 rate guaranteed, signifying that it is dust-proof and submersion in water up to 1 meter.
- Flexible stainless steel bracket, 360° rotation x 180° tilt.
- 60° Flood and 30° Spot for options.
- Reverse polar protection & leakage protection.



60° Flood and
30° Spot for options